



The SPN6M SMART controller is an ECU (Electronic Control Unit) equipped with smart high side mosfets and redundant architecture.

It can handle up to 32 inputs and up to 32 outputs.

It can be easily and quickly implemented in a CAN BUS network as SLAVE, with CANopen protocols.

The polyurethane resin case makes the controller suitable for use on machines that operate in harsh work environments.



TECHNICAL FEATURES

MASTER CODE	SP.6MS.426
POWER SUPPLY	9-36 VDC – 60mA @ 24 VDC (STANDBY MODE)
INPUT	<p>TOTAL No. 32 INPUTS, SOFTWARE CONFIGURABLE AS:</p> <ul style="list-style-type: none"> • UP TO 32 DIGITAL INPUTS (HIGH SIDE) • UP TO 8 DIGITAL INPUTS (LOW SIDE) • UP TO 28 ANALOGIC INPUTS (0~40V) • UP TO 8 ANALOGIC INPUTS (4~20mA) • UP TO 4 FREQUENCY INPUTS (1~1000Hz)
OUTPUT	<p>TOTAL No. 32 OUTPUTS, SOFTWARE CONFIGURABLE AS:</p> <ul style="list-style-type: none"> • UP TO 16 PWM HIGH SIDE OUTPUTS • UP TO 32 HIGH SIDE OUTPUTS (MAX 2A FOR EACH OUTPUT PIN) → MAX TOTAL HIGH SIDE OUTPUTS CURRENT 10 A) • UP TO 8 DIGITAL LOW SIDE OUTPUT (MAX 500mA FOR EACH OUTPUT PIN)
CAN BUS	No. 1 PORT: 2.0B COMPLIANT - (11, 29 BIT) - ISO 11898 - UP TO 1MBIT/S
CAN BUS PROTOCOLS	CAN OPEN (CIA DS401 DEVICE PROFILE FOR GENERIC I/O MODULE, WITH DS306 EDS FILE)
OPTIONALS	RTC (real time clock) Additional 2nd CAN-BUS PORT
CONNECTION <i>See «MATING CONNECTORS» table</i>	MOLEX 48 PIN CONNECTOR
CASE	PUR UL94-V0
PROTECTION	IP68
WORKING TEMPERATURE	-40°C +85°C



Scan me



ELECTRONIC FEATURES

SLAVE USAGE	EDS FILE
PROGRAMMING	FIRMWARE UPLOAD BY CAN BUS WITH ALOADER SOFTWARE TOOL
CYCLE TIME	Less than 0,5 ms
CPU	PIC 16 bit
INTERNAL MEMORY	FLASH: 192 KB (PROGRAM MEMORY: 164 KB) EEPROM: 64 KB

STANDARDS

DIRECTIVE	2014/30/EU (EMC)
ELECTROMAGNETIC COMPATIBILITY	EN 50498
ELECTROMAGNETIC EMISSIONS	EN 61000-6-4
ELECTROMAGNETIC IMMUNITY	EN 61000-6-2
ROAD VEHICLES ELECTRICAL DISTURBANCES FROM CONDUCTION AND COUPLING — PART 2	ISO 7637-2: 2011
ROAD VEHICLES COMPONENT TEST METHODS FOR ELECTRICAL DISTURBANCES FROM NARROWBAND RADIATED ELECTROMAGNETIC ENERGY — PART 1	ISO 11452-1: 2005
PERFORMANCE AND SAFETY INTEGRITY LEVEL	PLd – SIL2 (DUAL-CHANNEL INTERNAL SCHEME)

SIZE (mm)

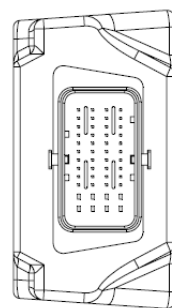
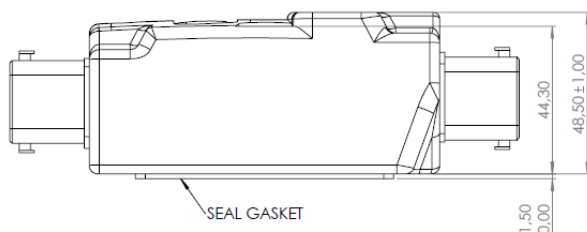
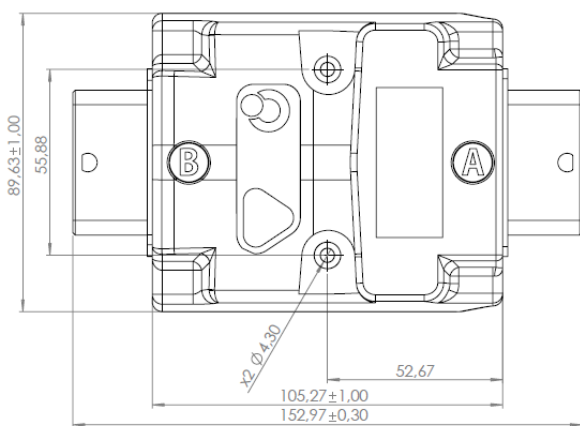

CPU B ON CONNECTOR B

CPU A ON CONNECTOR A



BOARD STATUS
CAN STATUS
DEVICE DIAGNOSTIC

Fix the unit with Hex socket head screws of stainless steel and a sealing washer.



→ **A** CONNECTOR

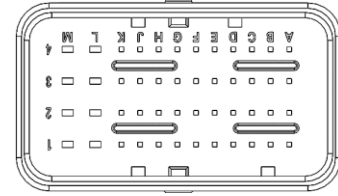

48 PINS A CONNECTOR PINOUT TABLE

PIN	A	B	C	D	E	F	G	H	J	K	L	M
1	DIGITAL / PWM OUTPUT 13	SUPPLY OUTPUTS 9...16	DIGITAL / PWM OUTPUT 12	DIGITAL / PWM OUTPUT 11	DIGITAL / PWM OUTPUT 10	DIGITAL / PWM OUTPUT 9	GND POWER SUPPLY	DIGITAL OUTPUT 8	DIGITAL OUTPUT 7	DIGITAL OUTPUT 6	SUPPLY OUTPUTS 1...8	DIGITAL OUTPUT 4
2	DIGITAL / PWM OUTPUT 14	INPUT 9 0...40Vdc/ DIGITAL	INPUT 8 0...40Vdc/ DIGITAL	INPUT 7 0...40Vdc/ DIGITAL	INPUT 6 4...20mA / 0...40Vdc/ DIGITAL	INPUT 5 4...20mA / 0...40Vdc/ DIGITAL	INPUT 4 4...20mA / 0...40Vdc/ DIGITAL	INPUT 3 4...20mA / 0...40Vdc/ DIGITAL	INPUT 2 0...40Vdc/ DIGITAL	INPUT 1 0...40Vdc/ DIGITAL	DIGITAL OUTPUT 5	DIGITAL OUTPUT 3
			DIGITAL OUTPUT LOW SIDE 4	DIGITAL OUTPUT LOW SIDE 3					DIGITAL OUTPUT LOW SIDE 2	DIGITAL OUTPUT LOW SIDE 1		
3	DIGITAL / PWM OUTPUT 15	INPUT 10 0...40Vdc/ DIGITAL	FREQ/ DIGITAL INPUT 11	FREQ/ DIGITAL INPUT 12	INPUT 13 0...40Vdc/ DIGITAL	INPUT 14 0...40Vdc/ DIGITAL	INPUT 15 0...40Vdc/ DIGITAL	INPUT 16 0...40Vdc/ DIGITAL	CAN2H*	CAN2L*	GND POWER SUPPLY	DIGITAL OUTPUT 2
4	DIGITAL / PWM OUTPUT 16	SENSOR POWER SUPPLY	SENSOR POWER SUPPLY	SENSOR POWER SUPPLY	GND	GND	GND	CAN1H	CAN1L	DEVICE POWER SUPPLY (+)	GND	DIGITAL OUTPUT 1

TERMINAL WIRE SIZE: follow the manufacturer's mating connector specification

- from A1 to J4: 0.75 mm²
- from L1 to M4: 2.0 mm²

MATING CONNECTORS – MOLEX CODES

CONNECTOR	64320-3311
TERMINALS	64323-1029 (x8) 64322-1029 (x40)
WIRE CAP	64320-1301
ALMEC PRE-WIRED CONNECTOR	CNN.ML.48P.R.VD.CB (red cable)



64320-3311

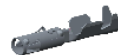

64323-1029



64322-1029



64320-1301



CNN.ML.48P.R.VD.CB

B CONNECTOR ON THE NEXT PAGE →

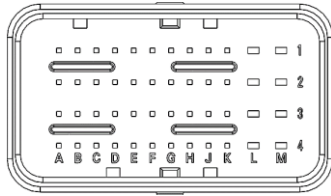

B CONNECTOR



48 PINS B CONNECTOR PINOUT TABLE

PIN	A	B	C	D	E	F	G	H	J	K	L	M
1	DIGITAL / PWM OUTPUT 29	SUPPLY OUTPUTS 25...32	DIGITAL / PWM OUTPUT 28	DIGITAL / PWM OUTPUT 27	DIGITAL / PWM OUTPUT 26	DIGITAL / PWM OUTPUT 25	GND POWER SUPPLY	DIGITAL OUTPUT 24	DIGITAL OUTPUT 23	DIGITAL OUTPUT 22	SUPPLY OUTPUTS 17...24	DIGITAL OUTPUT 20
2	DIGITAL / PWM OUTPUT 30	INPUT 25 0...40Vdc / DIGITAL	INPUT 24 0...40Vdc / DIGITAL	INPUT 23 0...40Vdc / DIGITAL	INPUT 22 4...20mA / 0...40Vdc / DIGITAL	INPUT 21 4...20mA / 0...40Vdc / DIGITAL	INPUT 20 4...20mA / 0...40Vdc / DIGITAL	INPUT 19 4...20mA / 0...40Vdc / DIGITAL	INPUT 18 0...40Vdc / DIGITAL	INPUT 17 0...40Vdc / DIGITAL	DIGITAL OUTPUT 21	DIGITAL OUTPUT 19
			DIGITAL OUTPUT LOW SIDE 24	DIGITAL OUTPUT LOW SIDE 23					DIGITAL OUTPUT LOW SIDE 18	DIGITAL OUTPUT LOW SIDE 17		
3	DIGITAL / PWM OUTPUT 31	INPUT 26 0...40Vdc / DIGITAL	FREQ / DIGITAL INPUT 27	FREQ / DIGITAL INPUT 28	INPUT 29 0...40Vdc / DIGITAL	INPUT 30 0...40Vdc / DIGITAL	INPUT 31 0...40Vdc / DIGITAL	INPUT 32 0...40Vdc / DIGITAL	CAN2H*	CAN2L*	GND POWER SUPPLY	DIGITAL OUTPUT 18
4	DIGITAL / PWM OUTPUT 32	SENSOR POWER SUPPLY	SENSOR POWER SUPPLY	SENSOR POWER SUPPLY	GND	GND	GND	CAN1H	CAN1L	DEVICE POWER SUPPLY (+)	GND	DIGITAL OUTPUT 17

TERMINAL WIRE SIZE: follow the manufacturer's mating connector specification

- from A1 to J4: 0.75 mm²
- from L1 to M4: 2.0 mm²

MATING CONNECTORS – MOLEX CODES

CONNECTOR	64320-3311
TERMINALS	64323-1029 (x8) 64322-1029 (x40)
WIRE CAP	64320-1301
ALMEC PRE-WIRED CONNECTOR	CNN.ML.48P.B.VD.CB (blue cable)



NOTES :

- «FREQ» means «frequency»
- (*) : CAN PORT 2 is an optional available on request
- Sensor power pins have the reference power supply voltage, MAX 200mA
- GND pins are connected together



ALMEC
MECHATRONICS

NOTE