



The SPLIFT is an ECU (Electronic Control Unit) suitable for dual DC motor drive and vehicle management systems.

The device has two proportional power channels for traction and steering control.

The onboard electronic is equipped with a redundant microcontroller, to ensure the failsafe operation and an integrated and configurable tilt sensor to limit or prevent selected functions when the vehicle is tilted.

A PC software tool (via RS232) allows system diagnosis, software updates and parametrization. The CAN SLAVE version allows to manage the device by a CAN BUS network.

TECHNICAL FEATURES	
MASTER CODE	SPL.444
POWER SUPPLY	18-30 VDC
INPUTS	No. 13+2* DIGITAL INPUTS (HIGH SIDE) No. 6 ANALOGUE INPUTS (0-5 VDC)
OUTPUTS	No. 4+2* DIGITAL HS OUTPUTS (MAX 2 A) – SELF PROTECTED DRIVER No. 2 DIGITAL PWM OUTPUTS (MAX 2 A – MAX 200 Hz) No. 4 DIGITAL LS OUTPUTS (MAX 1,8 A)
SHARED PIN (*)	No. 2 pin software configurable as: DIGITAL OUTPUT DIGITAL HS OUTPUT (MAX 2 A)
POWER OUTPUTS	No. 2 POWER OUTPUTS for traction motor controller NOMINAL CURRENT PER CHANNEL: 100 A MAX CURRENT PER CHANNEL: 160 A MAX FREQUENCY: 20 KHz
POWER SUPPLY OUTPUT	VREF: 5 VDC (MAX 500 mA with PTC) VSENS: V ALIM (MAX 1,10 A with PTC)
CAN BUS	No. 1 PORT: 2.0B COMPLIANT - (11, 29 BIT) - ISO 11898 - UP TO 1MBIT/S PROTOCOL for CAN slave version: CAN OPEN (CIA DS401 DEVICE PROFILE FOR GENERIC I/O MODULE) WITH DS306 EDS FILE
SERIAL	No. 1 PORT: RS232
TILT SENSOR	± 0 to 10°
SIGNALATION	No. 3 device status leds (green, yellow, red)
CASE	ABS - UL94-V0 PLATE AND CONNECTORS: ZINKED FE360/ALLUMINIUM
PROTECTION	IP40
WORKING TEMPERATURE	-20 +60°C - STORAGE: -40 +85°C





## STANDARDS

DIRECTIVE	2014/30/EU (EMC)
ELECTROMAGNETIC COMPATIBILITY	EN 50498
ELECTROMAGNETIC EMISSIONS	EN 61000-6-4
ELECTROMAGNETIC IMMUNITY	EN 61000-6-2
PERFORMANCE LEVEL	ISO 13849-1:2015: PLd

## SIZE (mm)

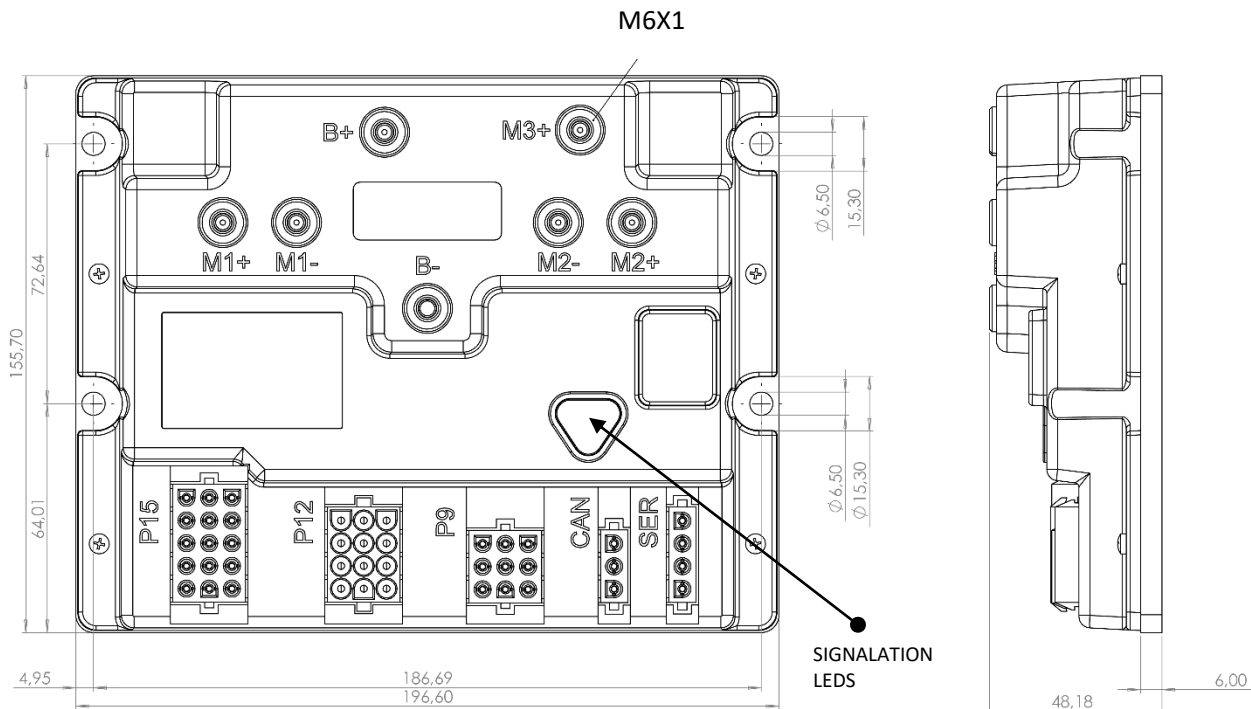

## MOUNTING INFORMATION

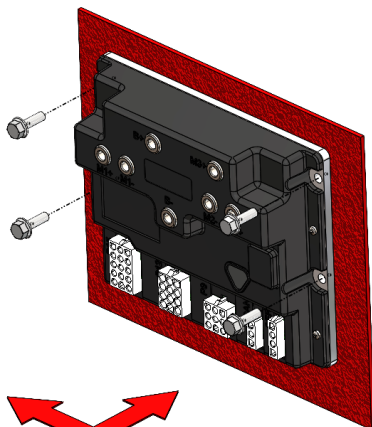

Direction of travel

<b>FIXING BOLT</b>	M6 - L ≥ 20 mm is recommended
<b>POSITION</b>	Wall mounting is needed. The device only operates in closed areas which are free from atmospheric agents: snow, rain and wind, etc.
<b>WORKING DIRECTION</b>	The plate must be set perpendicular to the floor and parallel or perpendicular to the direction of travel. P15-P12P9-CAN-SER connectors must be on the bottom
<b>WIRE DISPOSITION</b>	Wires must be downwards
<b>PLATE</b>	Plate is connected to the GND



CONNECTOR PINOUT

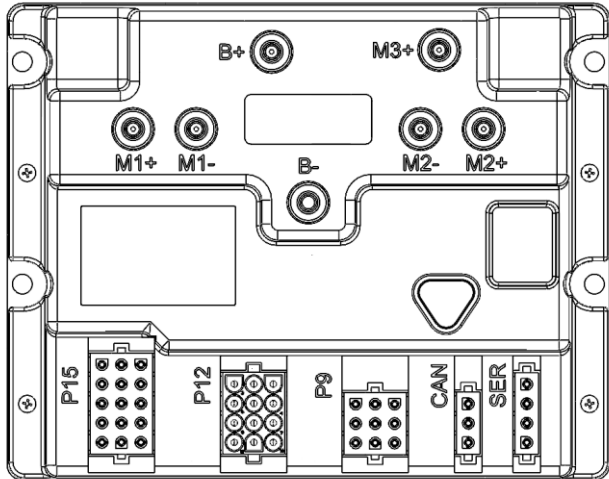

DES.	MATING PART	NOTE
M1 M2 M3 B	THREAD M6X1	LENGTH MAX: 16 mm (a spring washer add is suggested) MAX TORQUE: 2 Nm / 17,7 inlb
P15	50841150	MOLEX MLX POWER CONNECTION SERIES
P12	50841120	
P9	50841090	
CAN	50841030	
SER	50841040	

DES.	PIN	FUNCTION	DES.	PIN	FUNCTION
P9	1	DO HS PWM 1	P15	1	DI HS 8 & +V LOGIC PS
	2	DO HS PWM 2		2	DI HS 9
	3	DO HS 1		3	DI HS 10
	4	DO HS 2		4	DI LS 4
	5	DO HS 3		5	DI HS 11
	6	DO HS 4		6	DI HS 12
	7	DO HS 5		7	DI LS 5
	8	DI HS 1		8	DI HS 13
	9	DO HS 6		9	DI HS 14
P12	1	DI HS 2		10	DI LS 6
	2	DI HS 3/ DI LS 1		11	DI HS 15
	3	DI HS 4/ DI LS 2		12	VREF +
	4	DI HS 5		13	AIN 5
	5	DI HS 6		14	AIN 6
	6	DI LS 3		15	GND LOGIC PS
	7	AIN 1	CAN	1	CAN H
	8	VSNS+		2	CAN L
	9	DI HS 7		3	CAN GND
	10	AIN 2	SERIAL	1	+
	11	AIN 3		2	RX
	12	AIN 4		3	TX
		4		GND	

DES.	PIN	FUNCTION
B	+	POSITIVE power output ps
	-	GND power output ps
M1	+	POSITIVE DC MOTOR power output 1
	-	GND DC MOTOR power output 1
M2	+	POSITIVE DC MOTOR power output 2
	-	GND DC MOTOR power output 2
M3	+	+VALIM power output



**ALMEC**  
MECHATRONICS

NOTE