



The TRS.TCM is an inclinometer sensor based on a double CPU and a double 3D MEMS accelerometer, in a fully redundant circuit scheme, with two independent analogic outputs.

The output transfer function is fully configurable by user.

It can be implemented as SLAVE in a CAN network.

The polyurethane resin case makes the device suitable for use on machines that operate in harsh work environments.

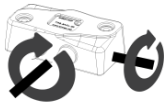

TILT  
MODALITY

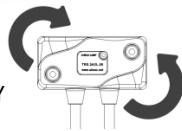

ANGULAR  
MODALITY

## TECHNICAL FEATURES

MASTER CODE		TRS.TCM
POWER SUPPLY		9-36 VDC / CURRENT CONSUMPTION 30 mA AT 24 VDC (STAND BY MODE)
OUTPUT OPTIONS		4 ÷ 20 mA – WITH PROGRAMMABLE OUTPUT SCALE FACTOR
		0 ÷ 5 VDC – WITH PROGRAMMABLE OUTPUT SCALE FACTOR
CAN BUS	1 PORT	2.0B COMPLIANT - (11, 29 BIT) - ISO 11898 - UP TO 1MBIT/S
CAN BUS PROTOCOLS		CAN OPEN (CIA DS410 DEVICE PROFILE FOR INCLINOMETER, WITH DS306 COMPLIANT EDS FILE)
LED		NR.1 STATUS LED
TECHNOLOGY		3D MEMS ACCELEROMETER
SAFETY		DOUBLE CPU AND DOUBLE SENSOR
MEASURE OPTIONS		ANGLE
		TILT
CONNECTION PORT	1	CABLE LENGHT: 30 cm CONNECTOR OPTIONS: MALE M12 8 PIN / DEUTSCH DT04-8P
CASE		ENCAPSULATED IN PUR RESIN - SELF-EXTINGUISHING UL94 (V0)
WORKING TEMPERATURE		-40°C +80°C





## ELECTRONIC FEATURES

SLAVE USAGE	EDS FILE	
PROGRAMMING	FIRMWARE UPLOAD BY CAN BUS WITH ALOADER SOFTWARE TOOL	
CONFIGURING	USING ALTILT CONFIG	
CPU	DOUBLE 16 bit MICROCONTROLLER CORE	
SAMPLE TIME	LESS THAN 5 ms	
MEASURING RANGE	TILT	0 - 360°
	ANGLE	-180°+180°
ACCURACY	TILT	0,01°
	ANGLE	0,1°

## OUTPUT FEATURES

0-5 V		4-20 mA	
MIN RESISTANCE LOAD	10 kΩ	MAX RESISTANCE LOAD	500 Ω
MIN OUTPUT VOLTAGE	0,5V	MIN OUTPUT CURRENT	4 mA
MAX OUTPUT VOLTAGE	4,5V	MAX OUTPUT CURRENT	20 mA
NUMBER OF OUTPUT STEPS	4096 (12 BIT)	NUMBER OF OUTPUT STEPS	4096 (12 BIT)

## STANDARDS

ELECTROMAGNETIC EMISSIONS	EN 61000-6-4// EN 55011 (RF RADIATE)
ELECTROMAGNETIC IMMUNITY	EN 61000-6-2// EN 61000-4-2/3/4/6
IP	BOX: IP68
MTTfd	214,04 YEARS CALCULATED ACCORDING TO THE IEC61709 (SIEMENS SN29500), WITH ENVIRONMENTAL FACTORS 3K7 (IEC60721)
PERFORMANCE AND SAFETY INTEGRITY LEVEL	PLd – SIL2 (DOUBLE-CHANNEL INTERNAL SCHEME)

IN ACCORDANCE WITH THE EN50498 THE DEVICE MEETS THE TECHNICAL SPECIFIC REQUIREMENTS OF 2004-104 DIRECTIVE (AUTOMOTIVE). THE DEVICE IS EMC 2004/108 COMPLIANT.

## SIZE (mm)

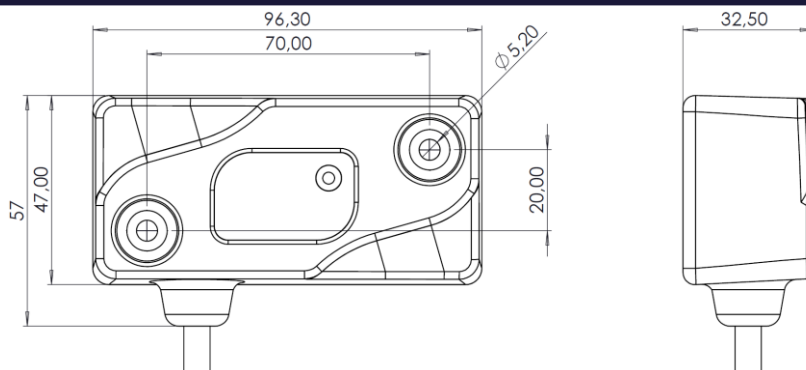



**PINOUT CONNECTOR**

DEUTSCH DT04-8P CONNECTOR			M12 – 8 PIN MALE CONNECTOR																		
PIN (C)	DESCRIPTION		PIN (C)	DESCRIPTION	<p>FRONT MALE VIEW</p> <table border="1"> <tr><td>1</td><td>white</td></tr> <tr><td>2</td><td>brown</td></tr> <tr><td>3</td><td>green</td></tr> <tr><td>4</td><td>yellow</td></tr> <tr><td>5</td><td>gray</td></tr> <tr><td>6</td><td>pink</td></tr> <tr><td>7</td><td>blue</td></tr> <tr><td>8</td><td>red</td></tr> </table>	1	white	2	brown	3	green	4	yellow	5	gray	6	pink	7	blue	8	red
1	white																				
2	brown																				
3	green																				
4	yellow																				
5	gray																				
6	pink																				
7	blue																				
8	red																				
1 (BN)	POSITIVE POWER SUPPLY	1 (WH)	POSITIVE POWER SUPPLY																		
2 (WH)	GND POWER SUPPLY	2 (BN)	CAN H																		
3 (YE)	CAN L	3 (GN)	CAN L																		
4 (OR)	CAN H	4 (YE)	GND																		
5 (BU)	ANALOG OUTPUT A.1	5 (GY)	ANALOG OUTPUT A.1																		
6 (BK)	ANALOG OUTPUT A.2	6 (PK)	ANALOG OUTPUT A.2																		
7 (VT)	ANALOG OUTPUT B.1	7 (BU)	ANALOG OUTPUT B.1																		
8 (GY)	ANALOG OUTPUT B.2	8 (RD)	ANALOG OUTPUT B.2																		

LEGEND: ANALOG OUTPUT i,j: i = A,B: Axle; j = 1,2: Logic Unit

**MEASURE OPTIONS vs OUTPUT**

S01		S04	
TRASDUCER WITH ANGLE MEASUREMENT MODE ONLY ON Z AXIS (ANGLE MEASUREMENT)		TRASDUCER WITH ANGLE MEASUREMENT MODE ON X & Y AXIS (TILT MEASUREMENT)	

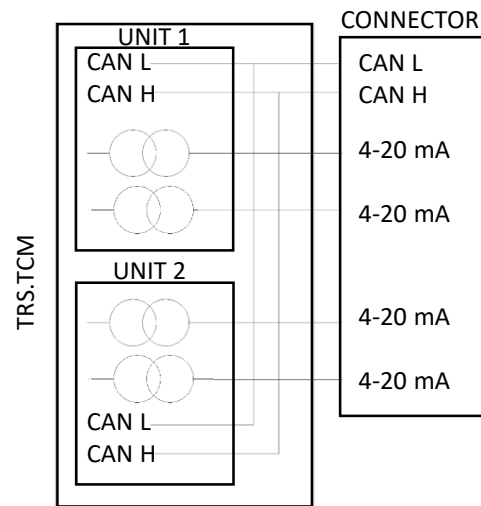
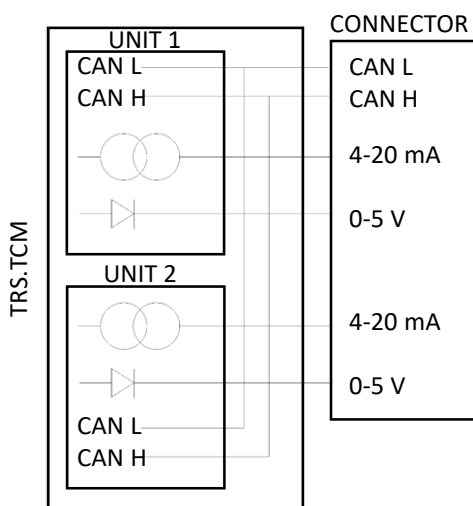

- ANALOG OUTPUT A.1 = 4..20mA Z axle, unit 1
- ANALOG OUTPUT A.2 = 4..20mA Z axle, unit 2
- ANALOG OUTPUT B.1 = 0..5V Z axle, unit 1
- ANALOG OUTPUT B.2 = 0..5V Z axle, unit 2

- ANALOG OUTPUT A.1 = 4..20mA X axle, unit 1
- ANALOG OUTPUT A.2 = 4..20mA X axle, unit 2
- ANALOG OUTPUT B.1 = 4..20mA Y axle, unit 1
- ANALOG OUTPUT B.2 = 4..20mA Y axle, unit 2



**ALMEC**  
MECHATRONICS

NOTE