



The SPN5M controller is an ECU (Electronic Control Unit) which can handle up to 16 inputs and up to 16 outputs.

Easy to program, using the ALMEClab development platform, it can be implemented in a serial line (RS232) or in a CAN network, as MASTER or SLAVE.

The polyurethane resin case makes the controllers suitable for use on machines that operate in harsh work environments.



TECHNICAL FEATURES

MASTER CODE		SPN5M
POWER SUPPLY		9-36 VDC / CURRENT CONSUMPTION 100 mA AT 24 VDC (STAND BY MODE)
INPUT	UP TO 16*	UP TO 16 DIGITAL INPUTS (HIGH SIDE) UP TO 14 ANALOGIC INPUTS (FULL RANGE 0..40V) UP TO 4 ANALOGIC INPUTS (4...20mA) UP TO 2 FREQUENCY INPUTS (HIGH SIDE UP TO 100Hz)
OUTPUT	UP TO 16*	UP TO 8 PWM HIGH SIDE OUTPUTS (MAX 2A FOR EACH OUTPUT PIN)** UP TO 16 HIGH SIDE OUTPUTS (MAX 2A FOR EACH OUTPUT PIN)** UP TO 4 LOW SIDE OUTPUTS – SHARED PIN WITH INPUTS (MAX 500mA FOR EACH OUTPUT PIN) UP TO 4 LOW SIDE OUTPUTS – SHARED PIN WITH INPUTS (MAX 30mA FOR EACH OUTPUT PIN)
CAN BUS	2 PORT	2.0B COMPLIANT - (11, 29 BIT) - ISO 11898 - UP TO 1MBIT/S
CAN BUS PROTOCOLS		CAN OPEN (CIA DS401 DEVICE PROFILE FOR GENERIC I/O MODULE, WITH DS306 EDS FILE) ON REQUEST: SAE J1939 - ISO 11783 (ISO BUS) - FMS
SERIAL PORT	1 PORT	RS232
RTC		NO (REFER TO THE SPN5M RTC VERSION)
CONNECTION PORT	1	MOLEX 48 PIN
CASE		PUR
WEIGHT		275 g
WORKING TEMPERATURE		-40°C +80°C



* See at the pinout table for the pin sharing. The pin function can be configured by software.

** Max total high side outputs current 12 A



ELECTRONIC FEATURES

SLAVE USAGE	EDS FILE
MASTER USAGE	ALMEClab
	STANDARD C PROGRAM LANGUAGE
PROGRAMMING	FIRMWARE UPLOAD BY CAN BUS WITH ALOADER SOFTWARE TOOL
CYCLE TIME	LESS THAN 2 ms
CPU	FAMILY: ARM CORTEX M4, 32BIT CORE
MEMORY	FLASH (PROGRAM MEMORY): 1MB RAM MEMORY: 256KB EEPROM: 128KB

STANDARDS

ELECTROMAGNETIC EMISSIONS	EN 61000-6-4// EN 55011 (RF RADIATE)
ELECTROMAGNETIC IMMUNITY	EN 61000-6-2// EN 61000-4-2/3/4/6
IP	BOX: IP68; CONNECTORS: IP67
MTTFd	MOSFET OUTPUT: 151,35 YEARS INPUT ONLY: 162,33 YEARS CALCULATED ACCORDING TO THE IEC61709 (SIEMENS SN29500), WITH ENVIRONMENTAL FACTORS 3K7 (IEC60721)
PERFORMANCE AND SAFETY INTEGRITY LEVEL	PLc – SIL1 (SINGLE-CHANNEL INTERNAL SCHEME)

IN ACCORDANCE WITH THE EN50498 THE DEVICE MEETS THE TECHNICAL SPECIFIC REQUIREMENTS OF 2004-104 DIRECTIVE (AUTOMOTIVE). THE DEVICE IS EMC 2004/108 COMPLIANT.

SIZE (mm)

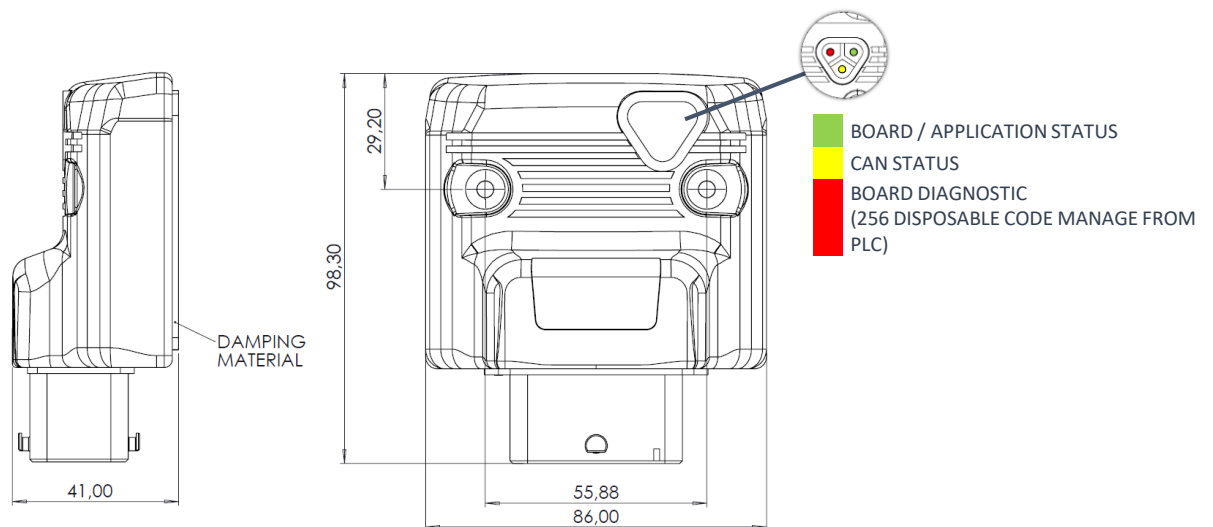



VERSION PORT AVAILABLE	
S01	Nr. 2 CAN OPEN PORTS
S02	Nr. 1 CAN OPEN PORT Nr. 1 RS232 PORT
S03	Nr. 2 CAN OPEN PORT Nr. 1 RS232 PORT

OTHER CUSTOMIZATIONS ARE AVIABLE ON REQUEST

COUPLING CONNECTORS - 48 PIN (MOLEX CODES)	
CONNECTOR	64320-3311
TERMINALS	64323-1029 (x8)
	64322-1029 (x40)
WIRE CAP	64320-1301



64320-3311



64323-1029



64322-1029



64320-1301

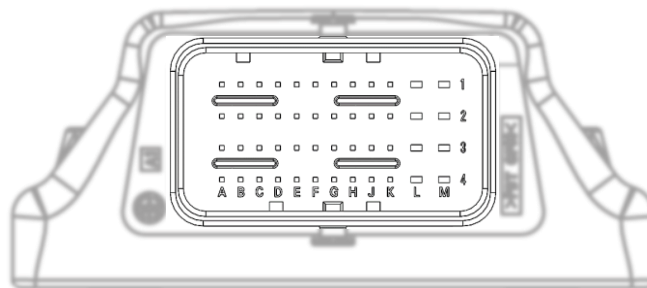

48 PINS CONNECTOR PINOUT TABLE

PIN	A	B	C	D	E	F	G	H	J	K	L	M
1	DIGITAL / PWM OUTPUT 13	SUPPLY OUTPUTS 9...16	DIGITAL / PWM OUTPUT 12	DIGITAL / PWM OUTPUT 11	DIGITAL / PWM OUTPUT 10	DIGITAL / PWM OUTPUT 9	GND POWER SUPPLY	DIGITAL OUTPUT 8	DIGITAL OUTPUT 7	DIGITAL OUTPUT 6	SUPPLY OUTPUTS 1...8	DIGITAL OUTPUT 4
2	DIGITAL / PWM OUTPUT 14	INPUT 9 0...40Vdc/ DIGITAL	INPUT 8 0...40Vdc/ DIGITAL	INPUT 7 0...40Vdc/ DIGITAL	INPUT 6 4...20mA / 0...40Vdc/ DIGITAL	INPUT 5 4...20mA / 0...40Vdc/ DIGITAL	INPUT 4 4...20mA / 0...40Vdc/ DIGITAL	INPUT 3 4...20mA / 0...40Vdc/ DIGITAL	INPUT 2 0...40Vdc/ DIGITAL	INPUT 1 0...40Vdc/ DIGITAL	DIGITAL OUTPUT 5	DIGITAL OUTPUT 3
			DIGITAL LS OUTPUT 8 500 mA	DIGITAL LS OUTPUT 7 500 mA	DIGITAL LS OUTPUT 6 30 mA	DIGITAL LS OUTPUT 5 30 mA	DIGITAL LS OUTPUT 4 30 mA	DIGITAL LS OUTPUT 3 30 mA	DIGITAL LS OUTPUT 2 500 mA	DIGITAL LS OUTPUT 1 500 mA		
3	DIGITAL / PWM OUTPUT 15	INPUT 10 0...40Vdc/ DIGITAL	FREQ / DIGITAL INPUT 11	FREQ / DIGITAL INPUT 12	INPUT 13 0...40Vdc/ DIGITAL	INPUT 14 0...40Vdc/ DIGITAL	INPUT 15 0...40Vdc/ DIGITAL	INPUT 16 0...40Vdc/ DIGITAL	RS232 RX / CAN2 H ***	RS232 TX / CAN2 L ***	GND POWER SUPPLY	DIGITAL OUTPUT2/ CAN2 L ****
4	DIGITAL / PWM OUTPUT 16	SENSOR POWER SUPPLY	SENSOR POWER SUPPLY	SENSOR POWER SUPPLY	GND	GND	GND	CAN H	CAN L	MODULE POWER SUPPLY	GND	DIGITAL OUTPUT1/ CAN2 H ****

*** FOR **S01**: CAN PORT 2 // FOR **S02**: SERIAL PORT// FOR **S03**: SERIAL PORT

**** FOR **S01**: DIGITAL OUTPUT // FOR **S02**: DIGITAL OUTPUT // FOR **S03**: CAN PORT 2

NOTE 1 : FOR DIGITAL LOW SIDE OUTPUTS : **DO NOT USE A LOW SIDE OUTPUT IF THE RELATIVE INPUT IS USED**

NOTE 2 : «FREQ» MEANS «FREQUENCY»



ALMEC
MECHATRONICS

NOTE